



**Toolholders with HSK-tapers shank DIN 69893-1**

**Holders for straight shank tools DIN 69882-4 (Weldon DIN 1835 B)**

Concentricity from the taper to the holding part < 0.005

Base-body balanced, G 2.5 - 20,000 r.p.m.

HSK-A100 - G2.5 - 15,000 r.p.m.



HSK-A

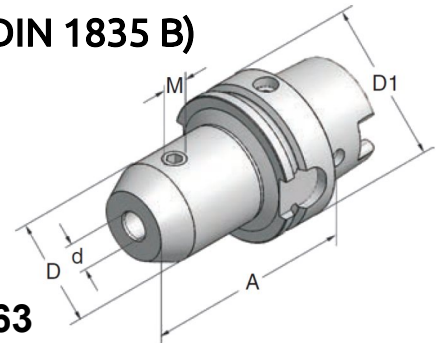

HSK - A 63

HSK - A



63.11.06.6 A=65



63.11.06.62 A=120



63.11.06.63 A=160



Art.-Nr.	Type	D1	A	d	D	M
63.11.06.6	HSK-A63x06x 65	63	65	6	25	6
63.11.06.620	HSK-A63x06x100	63	100	6	25	6
63.11.06.62	HSK-A63x06x120	63	120	6	25	6
63.11.06.63	HSK-A63x06x160	63	160	6	25	6
63.11.08.6	HSK-A63x08x 65	63	65	8	28	8
63.11.08.620	HSK-A63x08x100	63	100	8	28	8
63.11.08.62	HSK-A63x08x120	63	120	8	28	8
63.11.08.63	HSK-A63x08x160	63	160	8	28	8
63.11.10.6	HSK-A63x10x 65	63	65	10	35	10
63.11.10.620	HSK-A63x10x100	63	100	10	35	10
63.11.10.62	HSK-A63x10x120	63	120	10	35	10
63.11.10.63	HSK-A63x10x160	63	160	10	35	10
63.11.12.6	HSK-A63x12x 80	63	80	12	42	12
63.11.12.620	HSK-A63x12x100	63	100	12	42	12
63.11.12.62	HSK-A63x12x120	63	120	12	42	12
63.11.12.63	HSK-A63x12x160	63	160	12	42	12
63.11.14.6	HSK-A63x14x 80	63	80	14	44	12
63.11.14.62	HSK-A63x14x 20	63	120	14	44	12
63.11.16.6	HSK-A63x16x 80	63	80	16	48	14
63.11.16.620	HSK-A63x16x100	63	100	16	48	14
63.11.16.62	HSK-A63x16x120	63	120	16	48	14
63.11.16.63	HSK-A63x16x160	63	160	16	48	14
63.11.18.6	HSK-A63x18x 80	63	80	18	50	14
63.11.18.62	HSK-A63x18x120	63	120	18	50	14
63.11.20.6	HSK-A63x20x 80	63	80	20	52	16
63.11.20.62	HSK-A63x20x120	63	120	20	52	16
63.11.20.63	HSK-A63x20x160	63	160	20	52	16
63.11.25.6	HSK-A63x25x110	63	110	25	63	18x2
63.11.25.63	HSK-A63x25x160	63	160	25	63	18x2
63.11.32.6	HSK-A63x32x110	63	110	32	72	20x2
63.11.40.6	HSK-A63x40x120	63	120	40	64	16x1

We reserve the right to make technical changes.

## Toolholders with HSK-tapers shank DIN 69893-1

### Holders for straight shank tools DIN 69882-4 (Weldon DIN 1835 B)



HSK-A

HSK - A

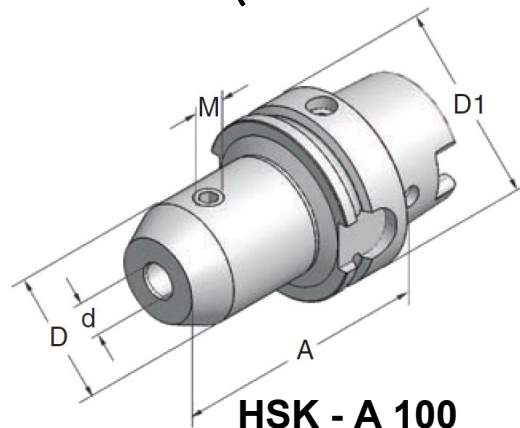

HSK - A 100



Art.-Nr.	Type	D1	A	d	D	M
100.11.20.6	HSK-A100x20x100	100	100	20	52	16
100.11.25.6	HSK-A100x25x100	100	100	25	63	18x2
100.11.32.6	HSK-A100x32x100	100	100	32	72	20x2
100.11.40.6	HSK-A100x40x120	100	120	40	80	20x2
100.11.50.6	HSK-A100x50x130	100	130	50	100	24x2



HSK-E

HSK - E

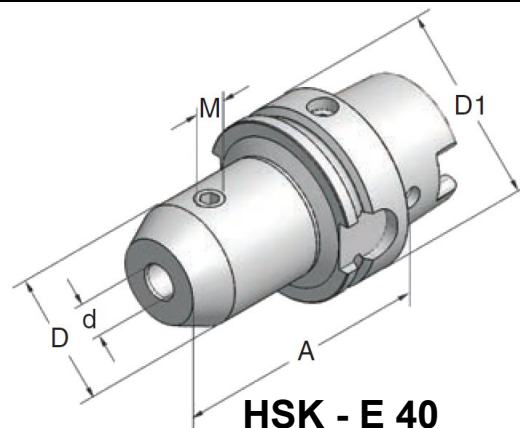

HSK - E 40



Art.-Nr.	Type	D1	A	d	D	M
40.12.06.6	HSK-E40x06x60	40	60	6	25	6
40.12.08.6	HSK-E40x08x60	40	60	8	28	8
40.12.10.6	HSK-E40x10x60	40	60	10	35	10
40.12.12.6	HSK-E40x12x70	40	70	12	42	12
40.12.16.6	HSK-E40x16x70	40	70	16	48	14
40.12.20.6	HSK-E40x20x70	40	70	20	44	16
<b>HSK - E 50</b>						
50.12.06.6	HSK-E50x06x65	50	65	6	25	6
50.12.08.6	HSK-E50x08x65	50	65	8	28	8
50.12.10.6	HSK-E50x10x65	50	65	10	35	10
50.12.12.6	HSK-E50x12x80	50	80	12	42	12
50.12.16.6	HSK-E50x16x80	50	80	16	48	14
50.12.20.6	HSK-E50x20x80	50	80	20	49	16

We reserve the right to make technical changes.

Holders for straight shank tools DIN 69882-4 (Weldon DIN 1835 B)



HSK-E

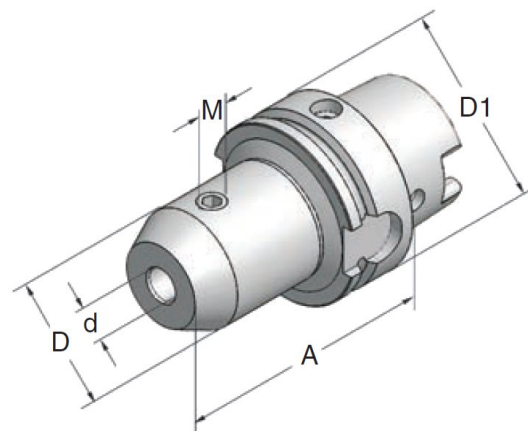

HSK - F

HSK - F 63

	Art.-Nr.	Type	D1	A	d	D	M
		63.13.06.6	HSK-F63x06x80	63	80	6	25
	63.13.08.6	HSK-F63x08x80	63	80	8	28	8
	63.13.10.6	HSK-F63x10x80	63	80	10	35	10
	63.13.12.6	HSK-F63x12x80	63	80	12	42	12
	63.13.14.6	HSK-F63x14x80	63	80	14	44	12
	63.13.16.6	HSK-F63x16x80	63	80	16	48	14
	63.13.18.6	HSK-F63x18x80	63	80	18	50	14
	63.13.20.6	HSK-F63x20x80	63	80	20	52	16
	63.13.25.6	HSK-F63x25x90	63	90	25	63	18x2
	63.13.32.6	HSK-F63x32x90	63	90	32	72	20x2

We reserve the right to make technical changes.