

## RAS

Tool group A19  
 Type 375-20 **RAKF**  
 for inserts with collet adapter

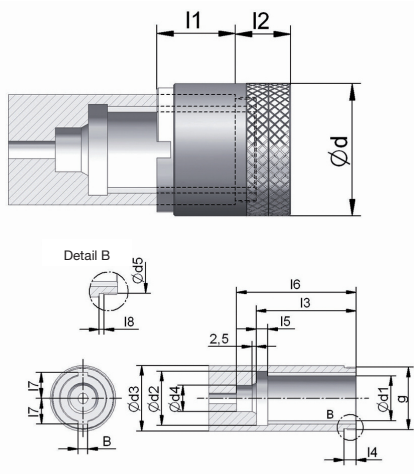

Item no.	d	d1	d2	d3	d4	d5	l2	l3	l4	l5	l6	l7	l8	B	g
601414	30	16	20	25	10	22,5	10	35	6,5	5	45	9,3	1,6	5	M24
601415	38	20	24	32	12	28,5	11	45	7,5	5	55	11,3	1,6	5	M30
601416	45	25	30	37	12	34,5	13	55	7,5	5	65	14,2	1,6	6	M36
601417	48	28	33	40	16	36,5	13	61	7,5	7	73	15,7	1,6	6	M38
601418	55	32	37	45	16	40	14	69,5	8	7	81,5	17,7	2,5	8	M42
601419	60	36	41	50	16	46	16	80	8,5	7	92	19,7	2,5	8	M48

Tool group A19  
 Type 375-60 Quick change adaptor **SEZ** (without collet)  
 For collets type ER/ESX DIN 6499 B

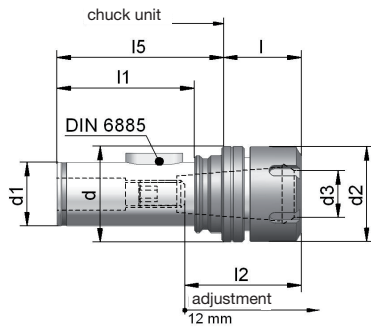

Item no.	Ø	Size	d	d1	d2	d3	l	l1	l2	l5
1132764	16	ER11	19	16	19	1 - 7	24	35	18 - 22	44,5
601420	16	ER16	28	16	32	1 - 10	27	35	27 - 31	44,5
784532	20	ER16	35	20	32	1 - 10	27	44	27 - 31	55
601421	20	ER20	35	20	35	1 - 13	28	55	31 - 37	67
601422	25	ER20	40	25	35	1 - 13	28	55	31 - 37	67
601423	25	ER25	42	25	42	1 - 16	30	55	35 - 40	67
601424	28	ER25	42	28	42	1 - 16	30	60	35 - 40	72
601425	28	ER32	42	28	50	2 - 20	38	60	40 - 46	72
601426	32	ER25	48	32	42	1 - 16	30	68	35 - 40	81,5
601427	32	ER32	48	32	50	2 - 20	38	68	40 - 46	81,5
601428	36	ER32	54	36	50	2 - 20	38	78	40 - 46	94
601429	36	ER40	54	36	63	3 - 26	41	78	46 - 51	94