



Turning Tools

Boring bars starting from 6 mm working diameter

90° / 95° approach angle, 80° corner angle

Carbide shank with internal coolant supply

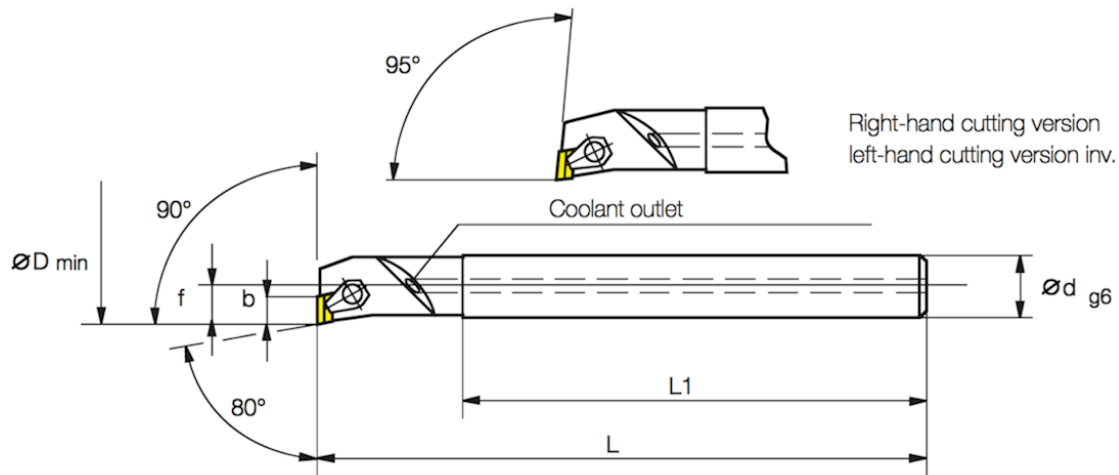

Part nr. 20034	Code	Drawing nr.	●	Ø D _{min}	Ø d	f	b	L ₁	L	Inserts*
90° approach angle										
6,000		HH8003-0600 0390R	●	6	6	3.25	3.00	70	100	W8003-...L
8,000		HH8005-0600 0490R	●	8	6	4.50	4.50	84	100	W8005-...L
10,000		HH8005-0800 0590R	●	10	8	5.50	4.50	105	125	I
12,000		HH8005-1000 0690R	●	12	10	6.50	4.50	126	150	↓
15,000		HH8008-1200 0890R	●	15	12	8.50	7.40	150	180	W8008-...L
20,000		HH8008-1600 1190R	●	20	16	11.00	7.40	160	200	↓
95° approach angle										
6,001		HH8003-0600 0395R	●	6	6	3.25	3.00	70	100	W8003-...L
8,001		HH8005-0600 0495R	●	8	6	4.50	4.50	84	100	W8005-...L
10,001		HH8005-0800 0595R	●	10	8	5.50	4.50	105	125	I
12,001		HH8005-1000 0695R	●	12	10	6.50	4.50	126	150	↓
15,001		HH8008-1200 0895R	●	15	12	8.50	7.40	150	180	W8008-...L
20,001		HH8008-1600 1195R	●	20	16	11.00	7.40	160	200	↓

*Please note: Left-hand boring bars have to be fitted with right-hand inserts and right-hand boring bars with left-hand inserts!

● ex stock

We reserve the right to make technical changes.



Turning Tools

Boring bars starting from 6 mm working diameter

90° / 95° approach angle, 80° corner angle

Carbide shank with internal coolant supply

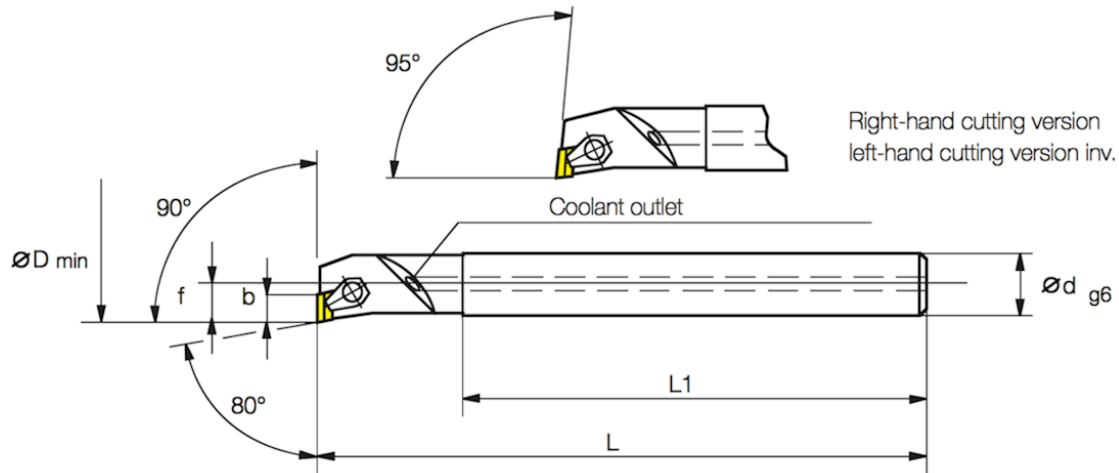

Part nr. 20035									
Code	Drawing nr.		Ø D _{min}	Ø d	f	b	L ₁	L	Inserts*
90° approach angle									
6,000	HH8003-0600 0390L	●	6	6	3.25	3.00	70	100	W8003-...R
8,000	HH8005-0600 0490L	●	8	6	4.50	4.50	84	100	W8005-...R
10,000	HH8005-0800 0590L	●	10	8	5.50	4.50	105	125	I
12,000	HH8005-1000 0690L	●	12	10	6.50	4.50	126	150	↓
15,000	HH8008-1200 0890L	●	15	12	8.50	7.40	150	180	W8008-...R
20,000	HH8008-1600 1190L	●	20	16	11.00	7.40	160	200	↓
95° approach angle									
6,001	HH8003-0600 0395L	●	6	6	3.25	3.00	70	100	W8003-...R
8,001	HH8005-0600 0495L	●	8	6	4.50	4.50	84	100	W8005-...R
10,001	HH8005-0800 0595L	●	10	8	5.50	4.50	105	125	I
12,001	HH8005-1000 0695L	●	12	10	6.50	4.50	126	150	↓
15,001	HH8008-1200 0895L	●	15	12	8.50	7.40	150	180	W8008-...R
20,001	HH8008-1600 1195L	●	20	16	11.00	7.40	160	200	↓

*Please note: Left-hand boring bars have to be fitted with right-hand inserts and right-hand boring bars with left-hand inserts!

● ex stock

We reserve the right to make technical changes.