



**Toolholders with HSK-tapers shank DIN 69893-1**

**Reducing adaptors MT DIN 228 form B with tang**

Concentricity from the taper to the holding part < 0.005

Base-body balanced, G 2.5 - 8,000 r.p.m.

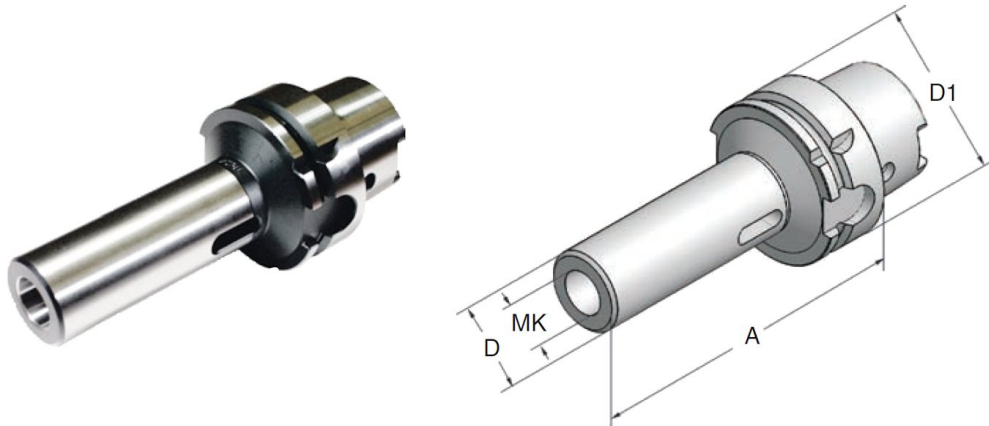

**HSK - A**

**HSK - A 63**

	Art.-Nr.	Type	D1	A	MK	D
	63.11.01.5	HSK-A63xMK1x100	63	100	1	25
	63.11.02.5	HSK-A63xMK2x120	63	120	2	32
	63.11.03.5	HSK-A63xMK3x140	63	140	3	40
	63.11.04.5	HSK-A63xMK4x160	63	160	4	48

**HSK - F**

**HSK - F 63**

	Art.-Nr.	Type	D1	A	MK	D
	63.13.01.5	HSK-F63xMK1x100	63	100	1	25
	63.13.02.5	HSK-F63xMK2x120	63	120	2	32
	63.13.03.5	HSK-F63xMK3x140	63	140	3	40
	63.13.04.5	HSK-F63xMK4x160	63	160	4	48

We reserve the right to make technical changes.

Reducing adaptors MT DIN 228 **form A with retention thread**

Concentricity from the taper to the holding part < 0.005

Base-body balanced, G 2.5 - 8,000 r.p.m.

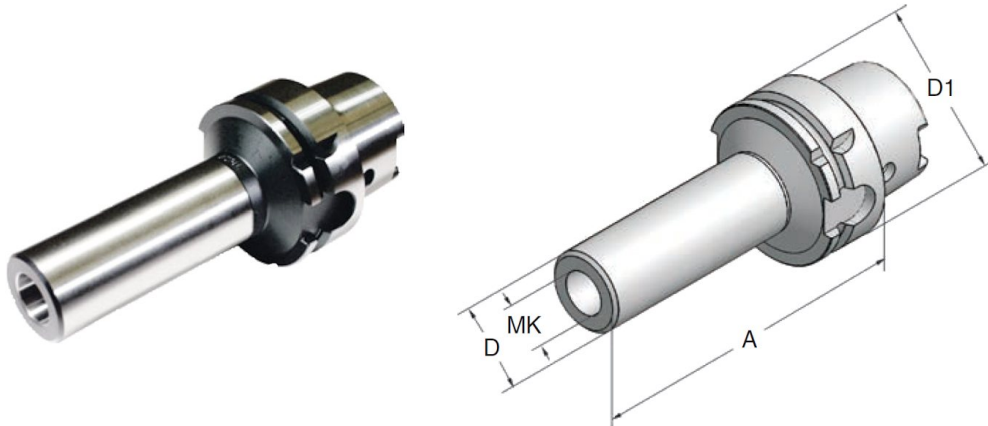

**HSK - A**

**HSK - A 63**

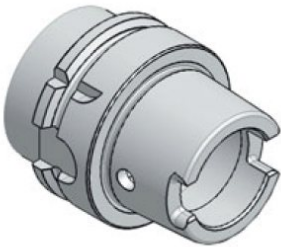
	Art.-Nr.	Type	D1	A	MK	D
	63.11.01.55	HSK-A63xMK1x100	63	100	1	25
	63.11.02.55	HSK-A63xMK2x120	63	120	2	32
	63.11.03.55	HSK-A63xMK3x140	63	140	3	40
	63.11.04.55	HSK-A63xMK4x165	63	165	4	48

We reserve the right to make technical changes.