



Toolholders with HSK-tapers shank DIN 69893-1

Shrinking chucks POWER-FLASH high-speed DIN 69882-8

**Best possible coolant supply through coolant channels in the boring
Concentrated coolant supply up to 20,000 r.p.m. to the cutting edge**

Base-body balanced, G 2.5 - 20,000 r.p.m.

Delivery without tool

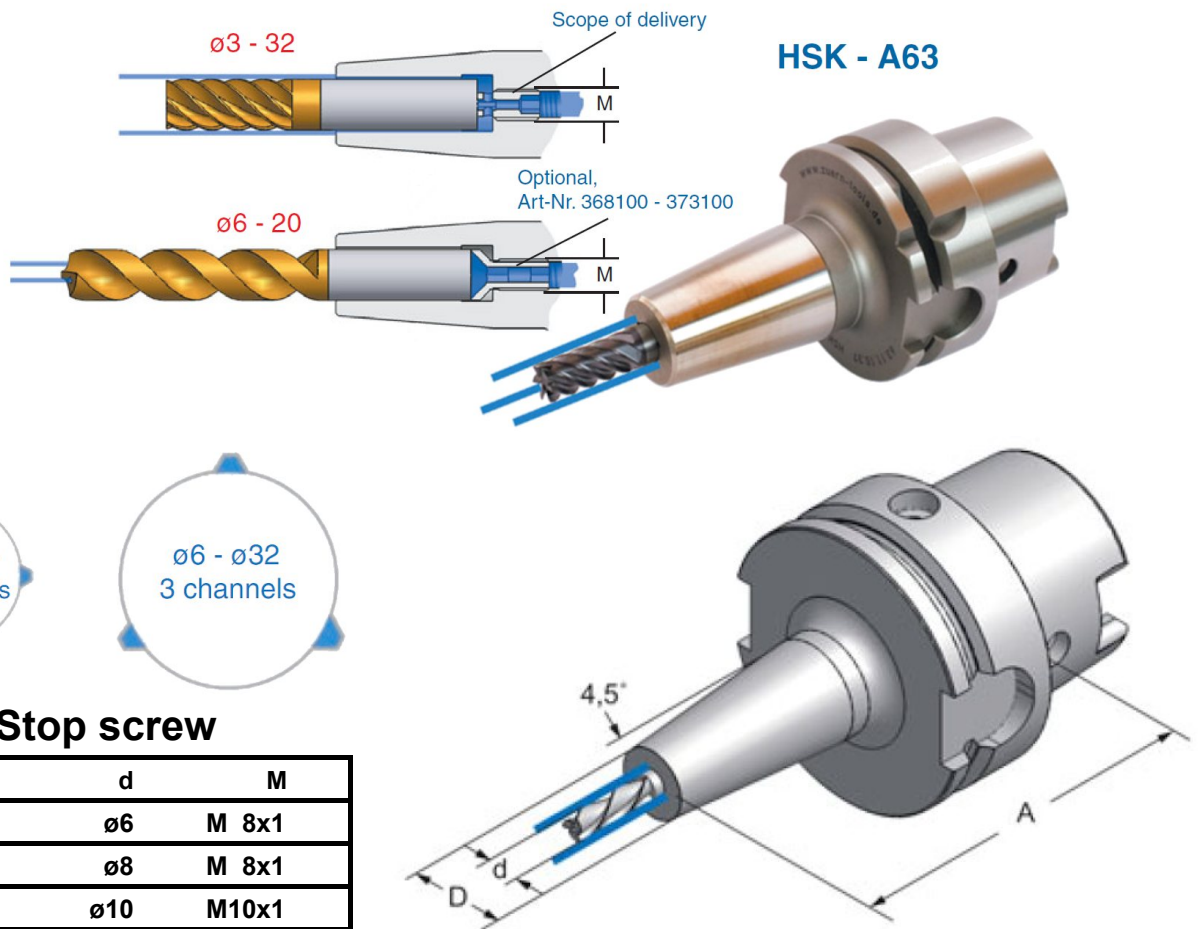

Stop screw

Art.-Nr.	d	M
368100	ø6	M 8x1
369100	ø8	M 8x1
370100	ø10	M10x1
370100-2	ø10	M 8x1
371100	ø12	M10x1
372100	ø16	M10x1
373100	ø20	M10x1

We reserve the right to make technical changes.

Shrinking chucks POWER-FLASH high-speed DIN 69882-8



Stop screw

Art.-Nr.	d	M
368100	ø6	M 8x1
369100	ø8	M 8x1
370100	ø10	M10x1
370100-2	ø10	M 8x1
371100	ø12	M10x1
372100	ø16	M10x1
373100	ø20	M10x1

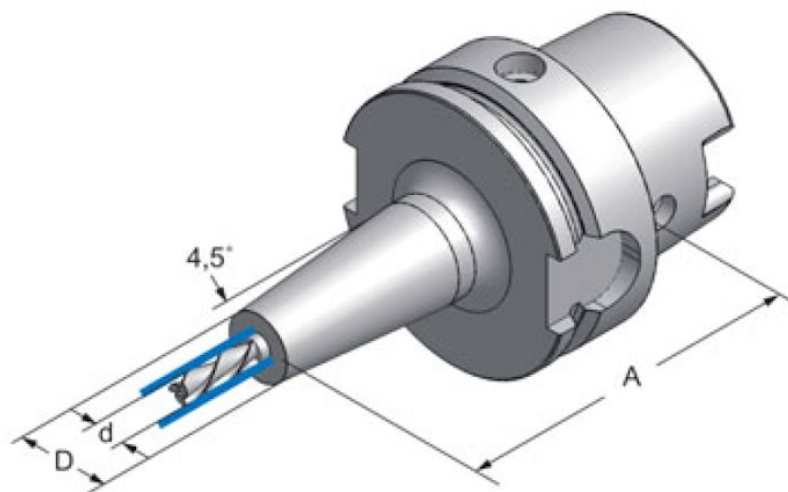

HSK - A

HSK - A 63

Art.-Nr.	Type	A	d	D	M
63.11.03.37	HSK-A63x03SCx 80	80	3	10	M6
63.11.04.37	HSK-A63x04SCx 80	80	4	11	M6
63.11.05.37	HSK-A63x05SCx 80	80	5	14	M8x1
63.11.06.37	HSK-A63x06SCx 80	80	6	16	M8x1
63.11.06.372	HSK-A63x06SCx130	130	6	16	M8x1
63.11.06.373	HSK-A63x06SCx160	160	6	21	M8x1
63.11.08.37	HSK-A63x08SCx 80	80	8	21	M8x1
63.11.08.372	HSK-A63x08SCx130	130	8	21	M8x1
63.11.08.373	HSK-A63x08SCx160	160	8	21	M8x1
63.11.10.37	HSK-A63x10SCx 85	85	10	24	M8x1
63.11.10.372	HSK-A63x10SCx130	130	10	24	M8x1
63.11.10.373	HSK-A63x10SCx160	160	10	24	M8x1
63.11.12.37	HSK-A63x12SCx 90	90	12	24	M10x1
63.11.12.372	HSK-A63x12SCx130	130	12	24	M10x1
63.11.14.37	HSK-A63x14SCx 90	90	14	27	M10x1
63.11.16.37	HSK-A63x16SCx 95	95	16	27	M10x1
63.11.16.372	HSK-A63x16SCx130	130	16	27	M10x1
63.11.18.37	HSK-A63x18SCx 95	95	18	33	M10x1
63.11.20.37	HSK-A63x20SCx100	100	20	33	M10x1
63.11.20.372	HSK-A63x20SCx130	130	20	33	M10x1
63.11.25.37	HSK-A63x25SCx100	100	25	44	M10x1
63.11.32.37	HSK-A63x32SCx100	100	32	44	M10x1

We reserve the right to make technical changes.