



Toolholders with HSK-tapers shank DIN 69893-1

Shrinking chucks POWER-FLASH high-speed DIN 69882-8

Best possible coolant supply through coolant channels in the boring
Concentrated coolant supply up to 20,000 r.p.m. to the cutting edge

Base-body balanced, G 2.5 - 20,000 r.p.m.

Delivery without tool

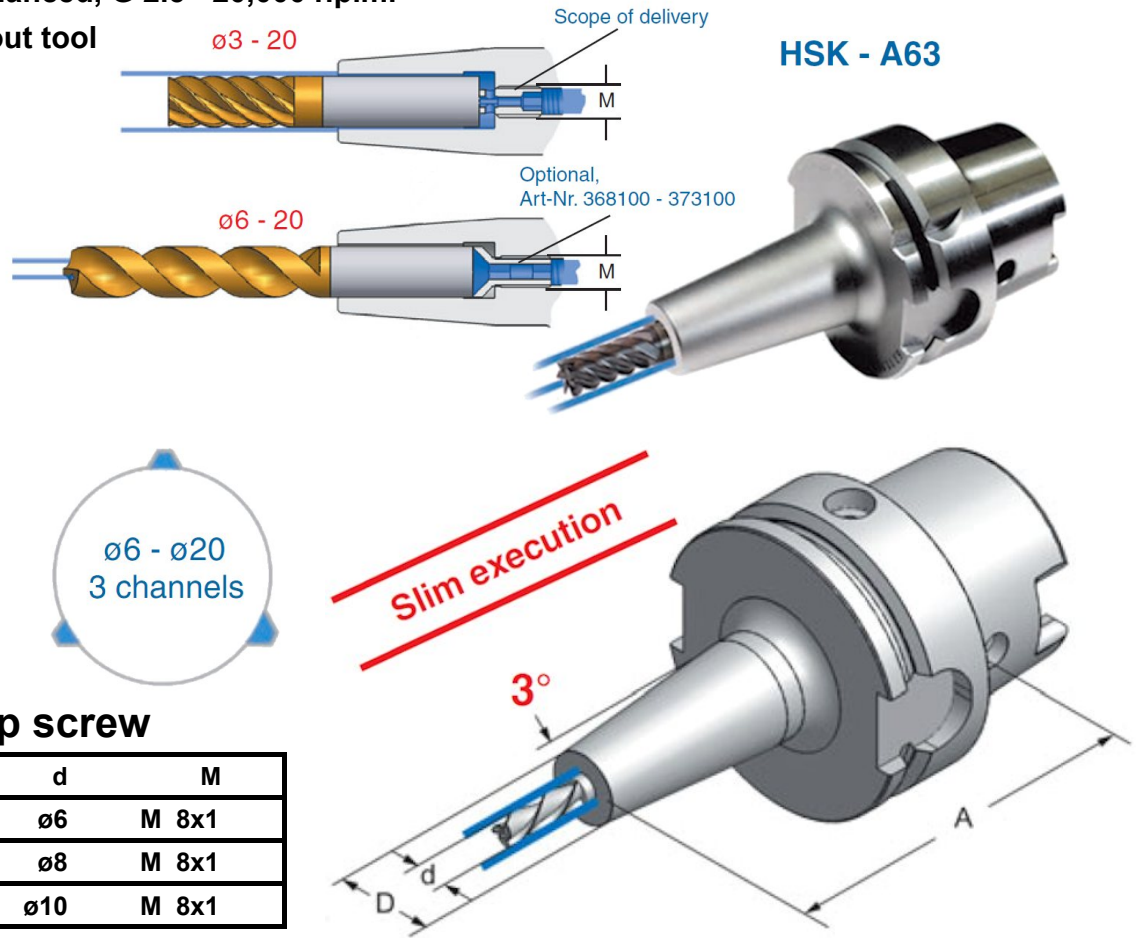

Stop screw

Art.-Nr.	d	M
368100	ø6	M 8x1
369100	ø8	M 8x1
370100-2	ø10	M 8x1

HSK - A

HSK - A 63

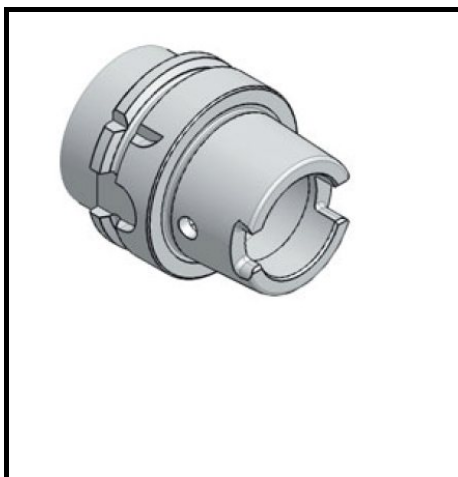

Art.-Nr.	Type	A	d	D	M	α
63.11.03.370	HSK-A63x03SCx80	80	3	9	M6	3°
63.11.04.370	HSK-A63x04SCx80	80	4	10	M6	3°
63.11.05.370	HSK-A63x05SCx80	80	5	11	M6	3°
63.11.06.370	HSK-A63x06SCx80	80	6	12	M8x1	3°
63.11.08.370	HSK-A63x08SCx80	80	8	14	M8x1	3°
63.11.10.370	HSK-A63x10SCx80	80	10	16	M8x1	3°
63.11.12.370	HSK-A63x12SCx80	80	12	18	M8x1	3°
63.11.14.370	HSK-A63x14SCx80	80	14	20	M8x1	3°
63.11.16.370	HSK-A63x16SCx80	80	16	22	M8x1	3°
63.11.20.370	HSK-A63x20SCx80	80	20	26	M8x1	3°

We reserve the right to make technical changes.