

Toolholders with HSK-tapers shank DIN 69893-1

Thread cutting quick-change chucks with smooth-action length compensation for pressure and tension

The tapping collet has to be ordered separately !



Größe 1 M3 - M12

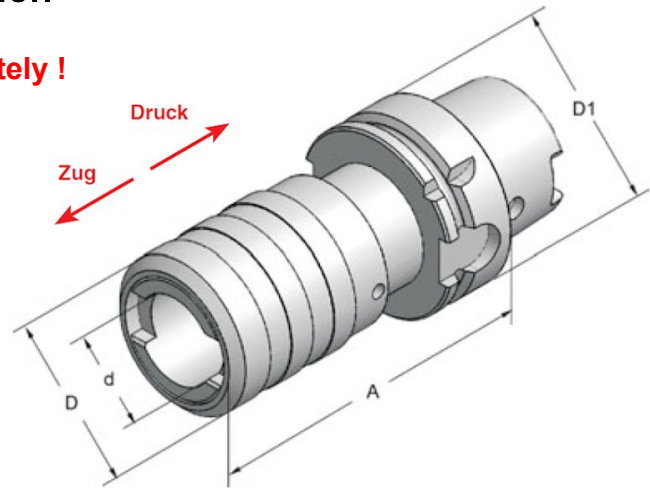

Größe 2 M8 - M20

Art.-Nr.	Type	D1	A	d	D	Art.-Nr.	Type	D1	A	d	D
HSK - A 50						HSK - A 50					
50.11.12.14	HSK-A 50xM3-M14	50	72	19	38	50.11.20.14	HSK-A 50xM8-M22	50	110	31	54
HSK - A 63						HSK - A 63					
63.11.12.14	HSK-A 63xM3-M14	63	72	19	38	63.11.20.14	HSK-A 63xM8-M22	63	110	31	54
HSK - A 100						HSK - A 100					
100.11.12.14	HSK-A100xM3-M14	100	80	19	38	100.11.20.14	HSK-A100xM8-M22	100	112	31	54

Tapping collets with clutch



Größe 1 M3 - M12

Größe 2 M8 - M20

Art.-Nr.	Type	Art.-Nr.	Type
100035	∅ 3.50 - M3+M4	200080	∅ 8.00 - M8+M11
100045	∅ 4.50 - M4+M6	200090	∅ 9.00 - M9+M12
100060	∅ 6.00 - M5+M6+M8	200100	∅10.00 - M10
100070	∅ 7.00 - M7+M9+M10	200110	∅11.00 - M14
100080	∅ 8.00 - M8+M11	200120	∅12.00 - M12+M16
100090	∅ 9.00 - M9+M12	200140	∅14.00 - M18
100100	∅10.00 - M10	200160	∅16.00 - M20

We reserve the right to make technical changes.