

Toolholders for CNC machines DIN 69880 / DIN ISO 10889

Axial toolholders form C1-C4 with internal coolant

- for clamping holders with coolant channels **directly to the cutting edge**
- for ISO-clamping holders **with claw clamping for best possible coolant supply**
- **with double tooling / coolant pressure up to 100 bar**

Delivery without tool

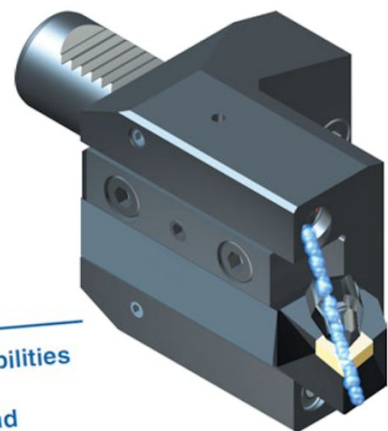
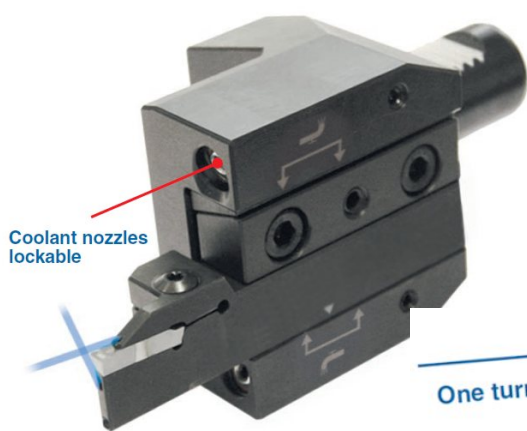

One turning-toolholder - four possibilities
Form C1, C2, C3, C4
left - right - forehead - overhead

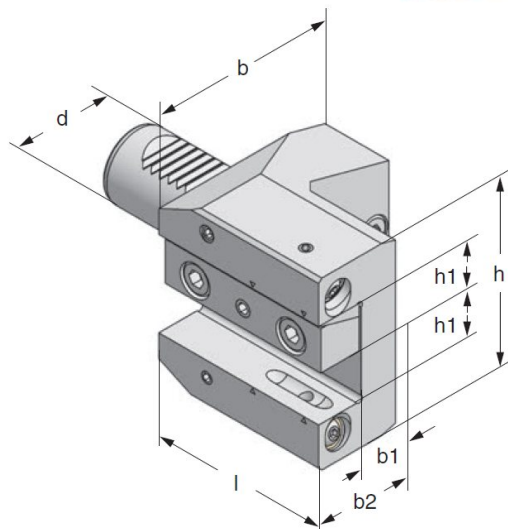

Standard DIN ISO

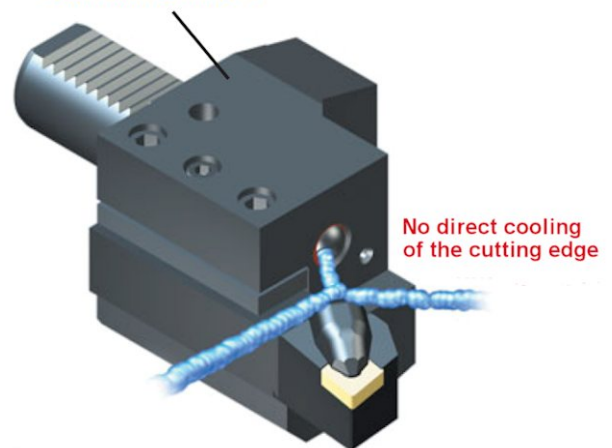

Art.-Nr.	Type	d	b	b1	b2	h	h1	l
30.20.043	C1-C4-30Dx20x 75	30	78	23.0	43.0	78	20	75
40.25.043	C1-C4-40Dx25x 90	40	94	27.5	52.5	94	25	90
50.25.043	C1-C4-50Dx25x100	50	105	38.0	63.0	100	25	100

We reserve the right to make technical changes.