

Toolholders for CNC machines DIN 69880 / DIN ISO 10889

Holder for insert drills form E1

Coolant supply internal

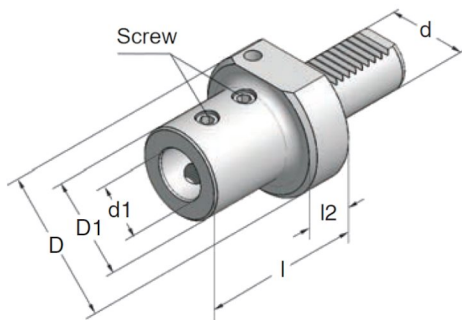

l1 = drill depth

Art.-Nr.	Type	d	d1	D	D1	l	l1	l2	Screw
20.16.220	E1-20x16x 60	20	16	50	34	60	54	18	114100
20.20.220	E1-20x20x 67	20	20	50	40	67	54	18	114100
20.25.220	E1-20x25x 71	20	25	50	45	71	59	18	122100
25.16.220	E1-25x16x 60	25	16	58	34	60	54	18	114100
25.20.220	E1-25x20x 67	25	20	58	40	67	54	18	114100
25.25.220	E1-25x25x 71	25	25	58	45	71	59	18	122100
25.32.220	E1-25x32x 71	25	32	58	52	71	63	18	122100
30.16.220	E1-30x16x 66	30	16	68	34	66	54	22	114100
30.20.220	E1-30x20x 67	30	20	68	40	67	54	22	114100
30.25.220	E1-30x25x 71	30	25	68	45	71	59	22	122100
30.32.220	E1-30x32x 75	30	32	68	52	75	63	22	122100
30.40.220	E1-30x40x 80	30	40	68	60	80	73	22	144100
40.16.220	E1-40x16x 66	40	16	83	34	66	54	22	114100
40.20.220	E1-40x20x 67	40	20	83	40	67	54	22	114100
40.25.220	E1-40x25x 75	40	25	83	45	75	59	22	122100
40.32.220	E1-40x32x 75	40	32	83	52	75	63	22	122100
40.40.220	E1-40x40x 90	40	40	83	60	90	73	22	144100
40.50.220	E1-40x50x 95	40	50	83	70	95	83	22	144100
50.20.220	E1-50x20x 67	50	20	98	40	67	54	30	114100
50.25.220	E1-50x25x 80	50	25	98	45	80	59	30	122100
50.32.220	E1-50x32x 80	50	32	98	52	80	63	30	122100
50.40.220	E1-50x40x 90	50	40	98	60	90	73	30	144100
50.50.220	E1-50x50x100	50	50	98	70	100	83	30	144100
60.20.220	E1-60x20x 80	60	20	123	40	80	54	30	114100
60.25.220	E1-60x25x 80	60	25	123	45	80	59	30	122100
60.32.220	E1-60x32x 80	60	32	123	52	80	63	30	122100
60.40.220	E1-60x40x 90	60	40	123	60	90	73	30	144100
60.50.220	E1-60x50x100	60	50	123	70	100	83	30	144100

We reserve the right to make technical changes.

Holder for insert drills form E1

Coolant supply internal

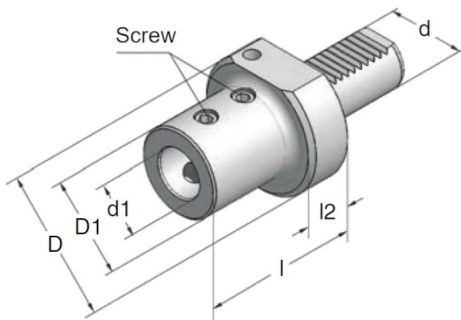

l1 = drill depth

Art.-Nr.	Type	d	d1	D	D1	l	l1	l2	Screw
INCH									
324206	E1-30x1" x71	30	1"	68	45	71	59	22	122100
325206	E1-30x1¼"x75	30	1¼"	68	52	75	63	22	122100
326206	E1-30x1½"x80	30	1½"	50	45	80	59	18	144100
424206	E1-40x1" x71	40	1"	83	45	71	59	22	122100
425206	E1-40x1¼"x75	40	1¼"	83	52	75	63	22	122100
426206	E1-40x1½"x90	40	1½"	83	60	90	73	22	144100
524206	E1-50x1" x71	50	1"	98	45	71	59	30	122100
525206	E1-50x1¼"x75	50	1¼"	98	52	75	63	30	122100
526206	E1-50x1½"x85	50	1½"	98	60	85	73	30	144100

We reserve the right to make technical changes.