

Toolholders for CNC machines DIN 69880 / DIN ISO 10889

**Boring bar holders Form E2
adjustable in height**

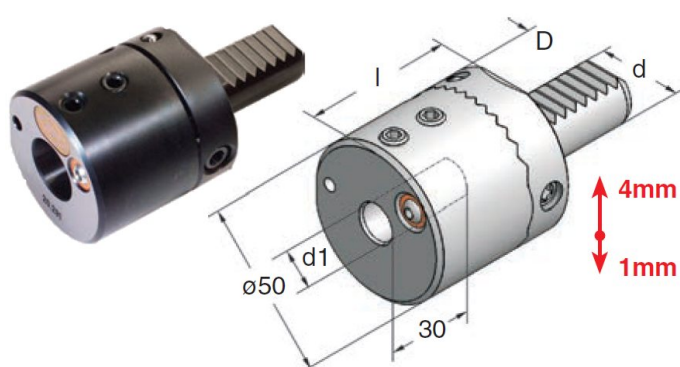

Art.-Nr.	Type	d	d1	D	l
20.08.291	E2-20x08x50	20	8	50	50
20.10.291	E2-20x10x50	20	10	50	50
20.12.291	E2-20x12x50	20	12	50	50
20.16.291	E2-20x16x50	20	16	50	50
20.20.291	E2-20x20x50	20	20	50	50
25.08.291	E2-25x08x50	25	8	58	55
25.10.291	E2-25x10x50	25	10	58	55
25.12.291	E2-25x12x50	25	12	58	55
25.16.291	E2-25x16x50	25	16	58	55
25.20.291	E2-25x20x50	25	20	58	55
30.08.291	E2-30x08x50	30	8	68	55
30.10.291	E2-30x10x50	30	10	68	55
30.12.291	E2-30x12x50	30	12	68	55
30.16.291	E2-30x16x50	30	16	68	55
30.20.291	E2-30x20x50	30	20	68	55

We reserve the right to make technical changes.