

Toolholders for CNC machines DIN 69880 / DIN ISO 10889

Broaching toolholder with cylindrical shank

Delivery without broaching cutter

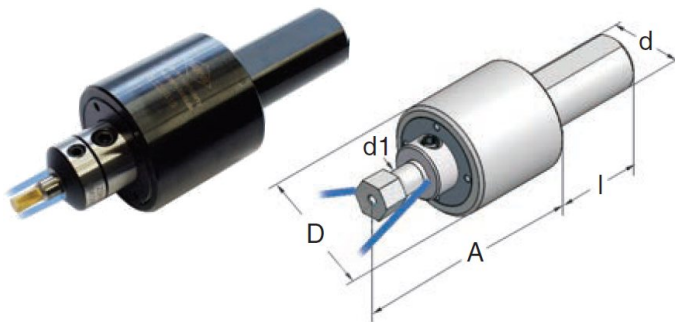

Art.-Nr.	Type	d	d1	l	D	A
16.08.5010	zyl. 16	16	8	38	40	65
20.08.5010	zyl. 20	20	8	38	40	65
22.08.5010	zyl. 22	22	8	48	40	65
25.08.5010	zyl. 25	25	8	48	40	65
INCH						
22.12.5010	zyl. 22	22	12	55	50	88
25.12.5010	zyl. 25	25	12	55	50	88
Heavy Execution						
1587.08.5010	zyl. 5/8"	15.875	8	38	40	65
1905.08.5010	zyl. 3/4"	19.05	8	38	40	65
2540.08.5010	zyl. 1"	25.4	8	48	40	65
Heavy Execution						
2540.12.5010	zyl. 1"	25.4	12	48	50	88
3175.12.5010	zyl. 1 1/4"	31.75	12	48	50	88
Heavy Execution						
40.12.5015	zyl. 40	40	12	100	70	121
50.12.5015	zyl. 50	50	12	100	70	121

Broaching toolholders DIN 69880

Delivery without broaching cutter

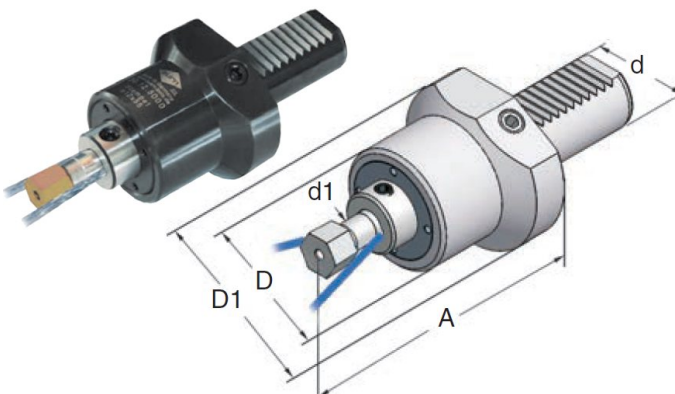

Art.-Nr.	Type	d	d1	D	D1	A
16.08.5000	VDI 16	16	8	40	44	70
20.08.5000	VDI 20	20	8	40	50	70
25.08.5000	VDI 25	25	8	40	58	70
Heavy Execution						
25.12.5000	VDI 25	25	12	50	58	96
30.12.5000	VDI 30	30	12	50	68	96
40.12.5000	VDI 40	40	12	50	83	96
Heavy Execution						
40.12.5005	VDI 40	40	12	70	83	121

We reserve the right to make technical changes.

Reduction

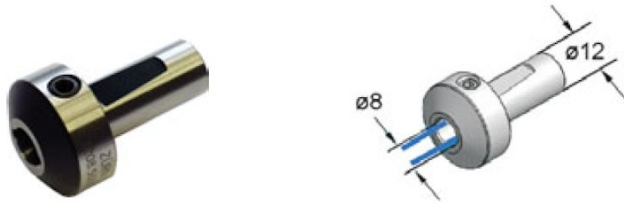

Art.-Nr.	Type
1208.5000	Reduction ø12/ø8

Control arbor



Art.-Nr.	d	l
08.5000	8	28
12.5000	12	55

Special executions on inquiry !

Hexagon-broaching cutters

TIN coated

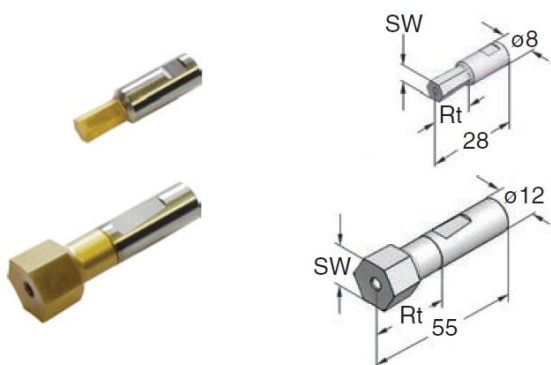

Art.-Nr.	SW	ø	Depth	Art.-Nr.	SW	ø	Depth
08.015	1.5	8	3	12.070	7	12	13
08.020	2	8	4	12.080	8	12	15
08.025	2.5	8	4	12.090	9	12	16
08.030	3	8	5	12.100	10	12	19
08.040	4	8	7	12.110	11	12	19
08.050	5	8	9	12.120	12	12	19
08.060	6	8	11	12.130	13	12	19
08.070	7	8	11	12.140	14	12	24
08.080	8	8	11	12.150	15	12	24
08.100	10	8	14	12.160	16	12	24
12.040	4	12	7	12.170	17	12	24
12.050	5	12	9	12.190	19	12	24
12.060	6	12	11	12.220	22	12	24

We reserve the right to make technical changes.

Hexagon-broaching cutters **INCH**

TIN coated

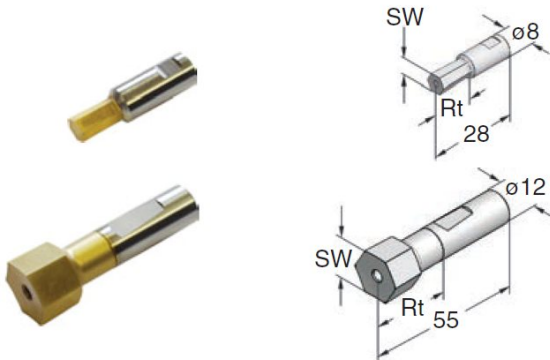

Art.-Nr.	SW	INCH	ø	Depth	Art.-Nr.	SW	INCH	ø	Depth
08.3/32	3/32"		8	4	08.5/16	5/16"		8	11
08.7/64	7/64"		8	4	08.3/8	3/8"		8	11
08.1/8	1/8"		8	5	12.1/4	1/4"		12	11
08.3/16	3/16"		8	9	12.3/8	3/8"		12	19
08.7/32	7/32"		8	9	12.7/16	7/16"		12	19
08.1/4	1/4"		8	11	12.1/2	1/2"		12	19

Broaching cutters TORX EN ISO 10664

TIN coated

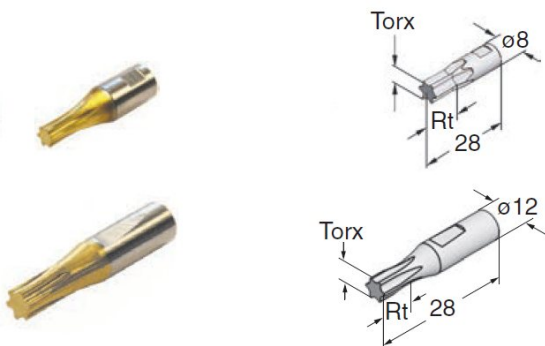

Art.-Nr.	TORX	ø	Depth	Art.-Nr.	TORX	ø	Depth
08.T05	5	8	3	08.T25	25	8	4
08.T06	6	8	3	08.T27	27	8	4
08.T07	7	8	3	08.T30	30	8	4
08.T08	8	8	3	08.T40	40	8	5
08.T09	9	8	3	08.T45	45	8	5
08.T10	10	8	3	12.T50	50	12	7
08.T15	15	8	3	12.T55	55	12	10
08.T20	20	8	4				

We reserve the right to make technical changes.